



**Capability Statement**

**Design Engineering  
Service**



**MARTEQ ENERGY** is a leading Project Delivery, Design Engineering, Project Management & Engineering Consultancy, Supply Chain servicing the Mining, Oil & Gas, Power Generation and Industrial infrastructure sectors.

## DESIGN ENGINEERING SERVICES

- 3D Design
- Technical Writing
- Structural and Mechanical Design
- Design and Drafting Services
- Infrastructure and Civil Design
- Electrical and Instrumentation Design
- Bucket Reclaimed Upgrade
- Specialized Design Engineering
- Basis of Design.
- Discipline Design Criteria.
- Technical specifications, such as pipe and valve specifications.
- Process Flow Diagrams & Mass Balance.
- Equipment Data Sheets.
- Engineering Master Deliverable Lists.



# DESIGN ENGINEERING SERVICES

MARTEQ ENERGY's team of experienced designers, engineers, and managers delivers precise designs that meet client specifications, focusing on quality and efficiency. We prioritize understanding project needs, ensuring designs are fit-for-purpose and on budget, while collaborating with clients for maximum value in as-built updates and changes.

## 1. 3D Design

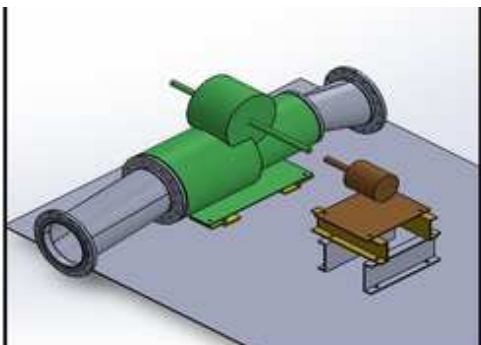

Using advanced 3D modeling and design software, we offer highly detailed and accurate visual representations of your projects. This ensures clarity, reduces errors, and helps to visualize the final product before implementation, saving time and costs.

## 2. Technical Writing

Clear and detailed technical documentation is crucial for project success. Our technical writing services provide clear, concise, and accurate specifications, manuals, and reports that support seamless communication between project stakeholders and ensure a smooth execution process.



## 3. Structural and Mechanical Design



MARTEQ ENERGY specializes in piping, structural, and mechanical design, offering defect analysis, risk assessment, and design improvements using advanced 3D software. Services include structural upgrades, FEA adequacy checks, and fabrication drawings.

## 4. Design and Drafting Services

Our innovative 3D design solutions streamline mechanical design, from concept models to fabrication-ready drawings. We offer technical documentation, renderings, and walkthroughs to showcase designs. Capabilities include chutes, tanks, piping, machine design, refits, 3D animations, and concept designs.

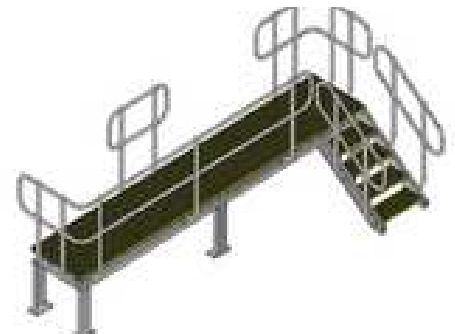

## 5. Infrastructure and Civil Design

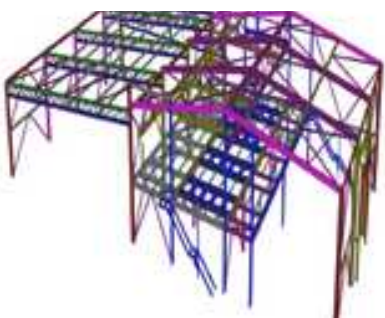

MARTEQ ENERGY offers multi-discipline capabilities in infrastructure and civil engineering, combining technical expertise with practical project experience. Our portfolio includes processing plant infrastructure, mine site developments, and designs for roads, hospitals, commercial buildings, car parks, and warehouses.

## 6. Electrical and Instrumentation Design

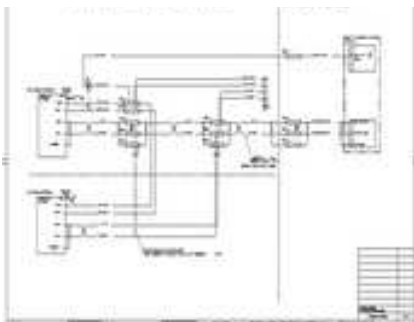

Our experienced electrical engineering team specializes in delivering projects of all sizes, from selection criteria to final commissioning. We provide value through refined processes, ensuring high-quality, cost-effective designs tailored to your project needs. Services include detailed electrical system design, technical reviews, commissioning work packs, and studies for protection, arc flash, and earthing.

## 7. Bucket Reclaimed Upgrade

MARTEQ ENERGY provided Finite Element Analysis (FEA) services, including a detailed analysis report with findings and recommendations. The scope included 3D scanning of bucket reclaimers, point cloud generation and review against 3D models, and design upgrades for extending equipment life at a mining site.

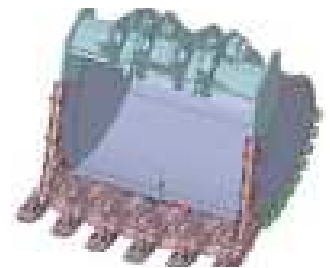

## 8. Specialized Design Engineering



MARTEQ ENERGY delivers specialized engineering services, including product design, FEA, structural audits, process applications, and electrical control solutions. We also offer design and certification for classified plants, such as pressure vessels, storage tanks, and lifting equipment. With extensive knowledge and experience, we meet diverse client needs efficiently.

## 9. Basis of Design

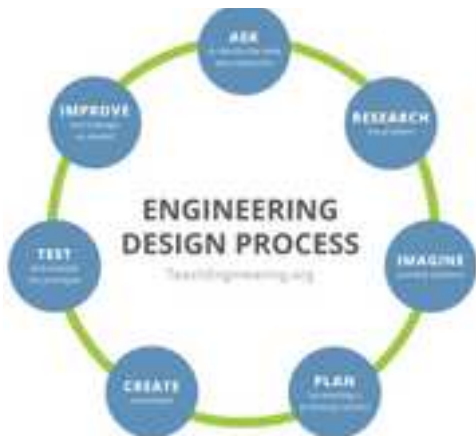

Our team designs safe, reliable, and efficient electrical and instrumentation systems for the mining, oil & gas, and power generation industries. We ensure that all electrical components meet regulatory standards and provide smooth operations from start to finish.

## 10. Discipline Design Criteria

Our engineers develop specific design criteria for each discipline involved in the project. This structured approach helps eliminate confusion, promotes consistency, and ensures all systems work in harmony with each other.

### Disciplinary Action Process Steps



## 11. Technical Specifications



We create precise technical specifications, such as pipe and valve specifications, to outline the requirements for all materials and components. This ensures that every piece of equipment meets the necessary performance and safety standards.

## 12. Process Flow Diagrams & Mass Balance

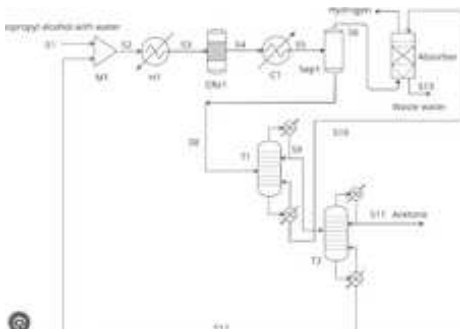

We create detailed process flow diagrams (PFDs) and mass balance models to visualize how materials and energy flow through your system. This allows us to optimize processes for maximum efficiency, cost savings, and performance.

## 13. Equipment Data Sheets

Our equipment data sheets contain all the essential information for each piece of equipment used in your project. These sheets include performance data, operational limits, and maintenance requirements, helping to ensure the reliability and longevity of your assets.



## 14. Engineering Master Deliverable Lists



To ensure projects stay on track and meet all milestones, we provide a comprehensive list of engineering deliverables. This detailed list helps streamline the workflow and ensures all required documents are delivered on time and to specification.

## OUR TECHNICAL RESOURCES

Our expertise in design software includes:

- Inventor
- Solid Works
- Product Data Management
- Smad3d (Isometric and PI&D's)
- AutoCAD
- Microstation including CAD Conform
- Creo
- SolidEdge



## INDUSTRY SECTORS

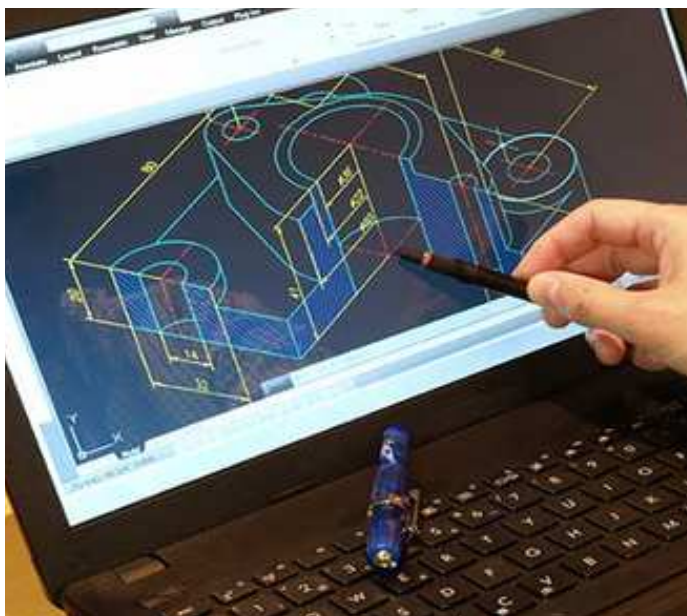

What Industries do we work with?

- Mining/Resources
- Infrastructure
- Mineral Processing
- Heavy Equipment
- Oil and Gas
- Product Design
- Agriculture Equipment



**Why Choose  
MARTEQ ENERGY  
for  
Your  
Design Engineering Needs?**

- Leader in design engineering for mining, oil & gas, and power generation industries.
- Comprehensive suite of services combining cutting-edge technology and expertise.
- Focus on enhancing safety, efficiency, and sustainability in engineering solutions.
- Commitment to quality, compliance, and client satisfaction.
- Designs optimized to meet operational goals and regulatory requirements.
- Trusted partner throughout all phases of the engineering process, from design to execution.
- Tailored solutions to elevate your projects with innovative engineering services.



Reach out to us to ensure the best solutions for your site

## MARTEQ ENERGY PTY LTD

### HEAD QUATERS:

 7/26 Hilditch Avenue Newman 6753 WA, Australia

### REGISTERED WAREHOUSE:

 4/231 Barrington Street Bibra Lake 6163 WA, Australia

### Tina Ewen

#### President

Mob: +61 0423229724

Email: Tina.ewen@marteqenergy.com.au

### Santhana Dass

#### Project Manager

Mob: +61 42155504

Email: Santhana.dass@marteqenergy.com.au

[www.marteqenergy.com.au](http://www.marteqenergy.com.au)